

Please read before assembly and installation of Feelux product

1. Before attempting to install or use fixture, read and understand the installation instructions and safety labels. If you have any questions, please contact Feelux Technical support at 678-668-7005 ext 4.
2. Feelux product must be installed by a qualified electrician in accordance with all national and local electrical and construction codes and regulations.
3. Ensure that the main power supply is off before installing or wiring a fixture.
4. Ensure that the power to the series is off before connecting or disconnecting individual fixtures.
5. Do not use a fixture if the unit, lens, housing or power cables are damaged.
6. Do not attempt to repair. Fixtures have no serviceable parts and there is risk of shock.
7. Do not use a fixture for any voltage for which it is not rated. Do not exceed the specified voltage and current input for any fixtures.
8. To complete cable and fixture connections, press together until there is an audible click.
9. To disconnect, twist apart. Do not pull apart.
10. The screws included are for millwork. Please use the appropriate screws for the application.
11. If using magnetic mounting, ensure that magnets and plates are properly aligned.
12. This device complies with Part 15 of the FCC rules.
13. Class B Digital Apparatus complies with Canadian ICES-003
14. Feelux FLX Stix fixtures are damp rated and closet approved.

Side Feed

Side Feed units provide uninterrupted continuous lines of light.
FLX Stix DDV requires a Side Feed unit for runs that exceed 75W or ~12'.
Side Feed units have factory installed power cable and require power.

Approved Drivers and Transformers

FLX Stix Series can be installed with the following approved drivers/transformers/power supplies:

- Feelux FLC and XLD Series Drivers
- Qtran Q6S, Q6M, QTM, QTM ELED. When dimming QTran QTM DC + CAP may be required.
- Eclipse Light Manager
- Lutron

Other drivers have not been tested and will not comply with the Feelux warranty.

Please read before assembly and Installation of Feelux Product (Continued)**Splicing**

When using Feelux XLD, QTran, or Eklipse, the driver end of the power feed cable is cut and spliced. HDVPC and SIDEFEED power cables are 8Ft long. Splice point connections to be located at 8Ft max from first fixture or sidefeed fixture. Drivers can be remote located. Contractor to provide low voltage wiring for remote distance application. Contractor must test for 24VDC at all splice points. Polarity must be followed and is:

FLX Stix DDV: See pages 4, 5 & 6

Lead: Writing - Positive

Lead: Gray Stripes - Negative

Lead: xxxxx - Positive

Lead: +++++ - Negative

Jumpers

Jumpers cannot be cut or spliced at any time without written permission from Feelux.

FLX Stix Dimming:

Please insure dimming signal compatibility prior to installation.

Feelux FLC AND XLD Driver: Dimming Interface, FDC-L10, is required. Dimming is 0-10V signal.

Eklipse Light manager: Dimming interface is not required. Dimming is 0-10v or DMX signal.

QTran: Q6S, Q6M and QTM: Dimming interface is not required.

Dimming is Forward Phase Magnetic Low Voltage.

DC + Capacitor may be required. Consult Feelux for compatibility.

QTM-ELED: Dimming is 0-10V signal.

Step 1. Verify electrical plan.

1. Calculate the number of fixtures each circuit can support based on: model of fixture, circuit load and cable length.
2. DDV can be loaded to 75W before side feed unit is required.
3. If you have questions, contact your local Feelux representative or Feelux.

Step 2. Check that all components are on site.

Step 3. Installation / Mounting

Always requires two person installation for fixture runs longer than 4 feet!
 FLX Stix Series are shipped with Standard Mounting Brackets and Magnetic Plates.
 Angled Mounting Brackets are ordered separately.
 Brackets are to be installed within 2" from ends of the unit to support the junction point.
 For fixture units of 2Ft or longer install a 3rd bracket near the middle.
 Bracket 3 is included and must be installed at all connection points.

Align all brackets using laser line

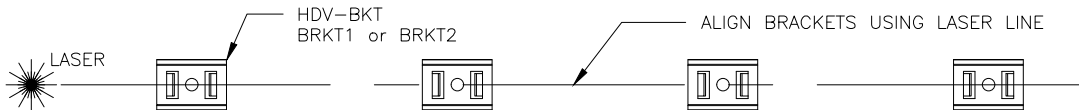

Mounting Option: Magnetic Mounting
 for use on ferrous metal surfaces.

1. Assemble fixtures
2. Snap fixtures on to ferrous metal surface

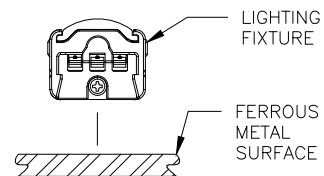

Mounting Option: Standard Brackets
 for use on wood surfaces.

1. Assemble fixtures
2. Align / Install Brackets using laser line
3. Snap fixtures into brackets

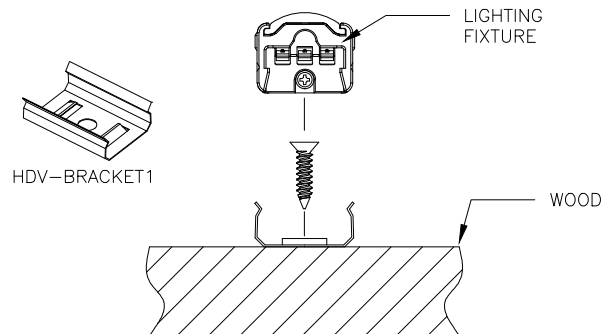

Mounting Option: Angled Brackets
 for use on wood surfaces.
 Brackets can be used
 40 degree and 15 degree
 mounting positions.

1. Assemble fixtures
2. Align / Install Brackets using laser line
3. Snap fixtures into Brackets

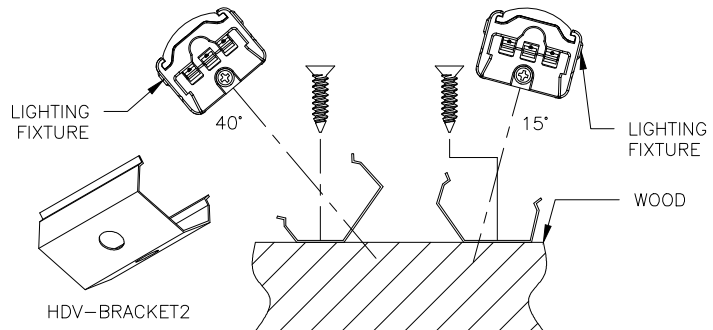

Mounting Option: Magnetic Mounting
 with Metal Plates to be
 used ONLY on glass surfaces,
 ONLY on horizontal positions.

1. Assemble fixtures
2. Place Metal Plates on magnets in the back of the fixtures
3. Peel off double stick tape
4. Holding the fixtures press the exposed tape side to the glass surface

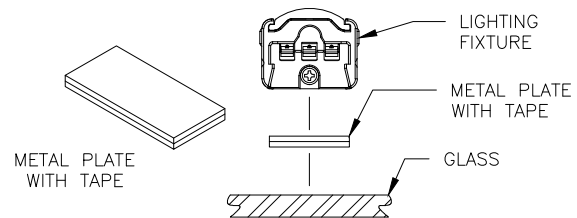

Step 4. Connecting Fixtures
0 - 10V Dimming

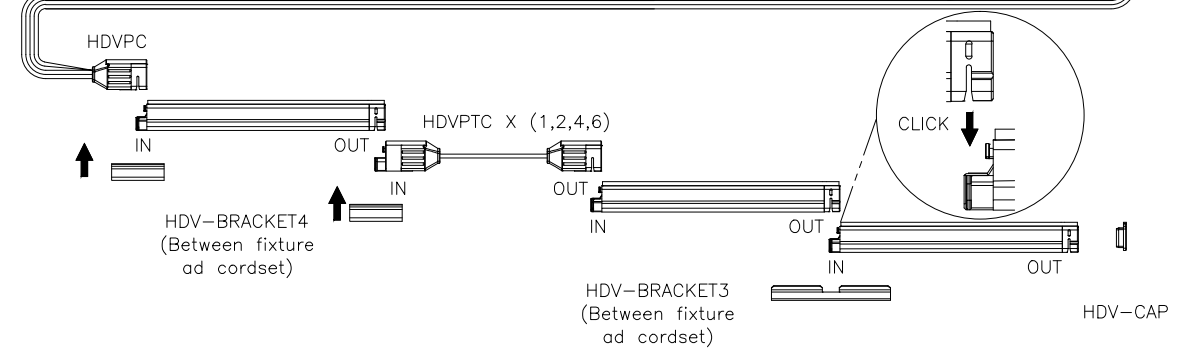
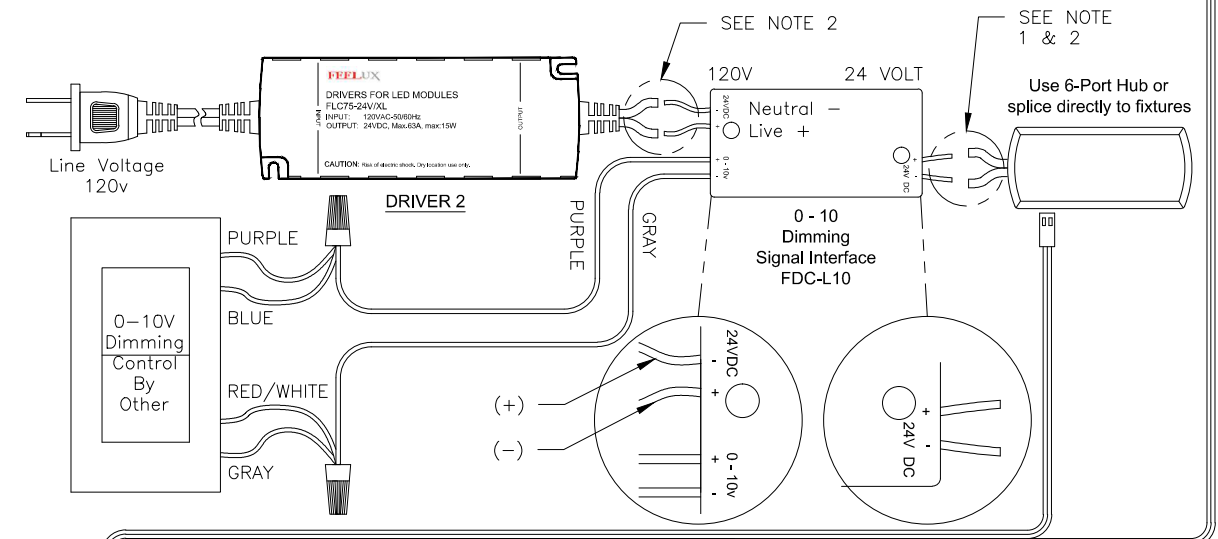
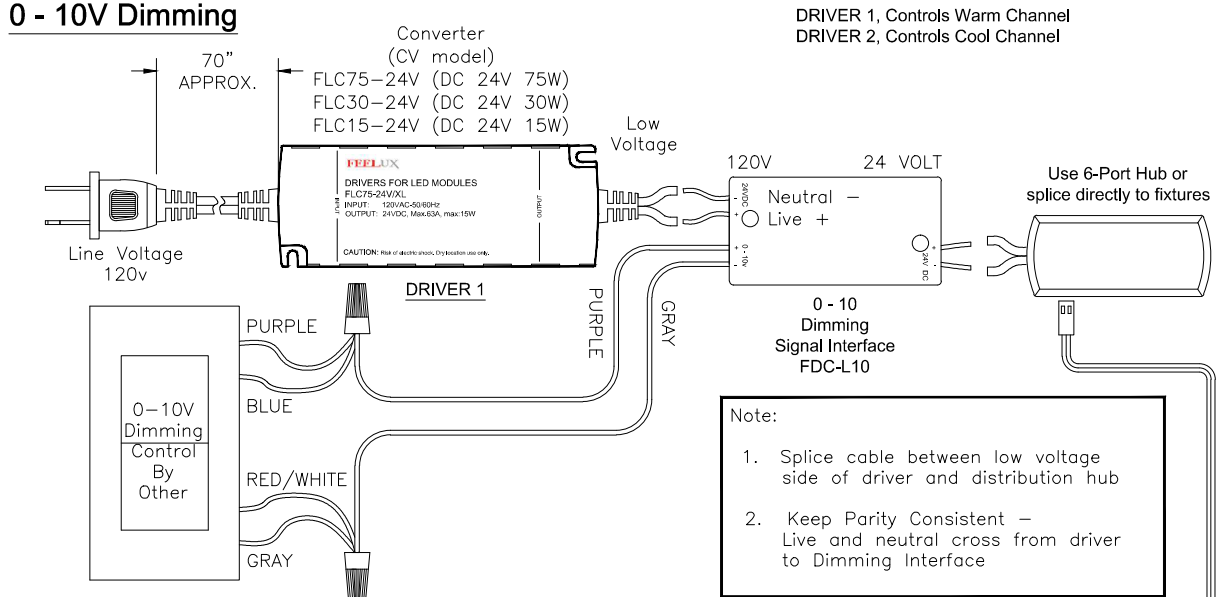

CAUTION: TOTAL CONNECTED FIXTURES WATTAGE NOT TO EXCEED DRIVER WATTAGE!

**Step 4. Driver and Fixture Installation (Continued) :
Dimming Wiring Instruction, 0 -10V Dimming**

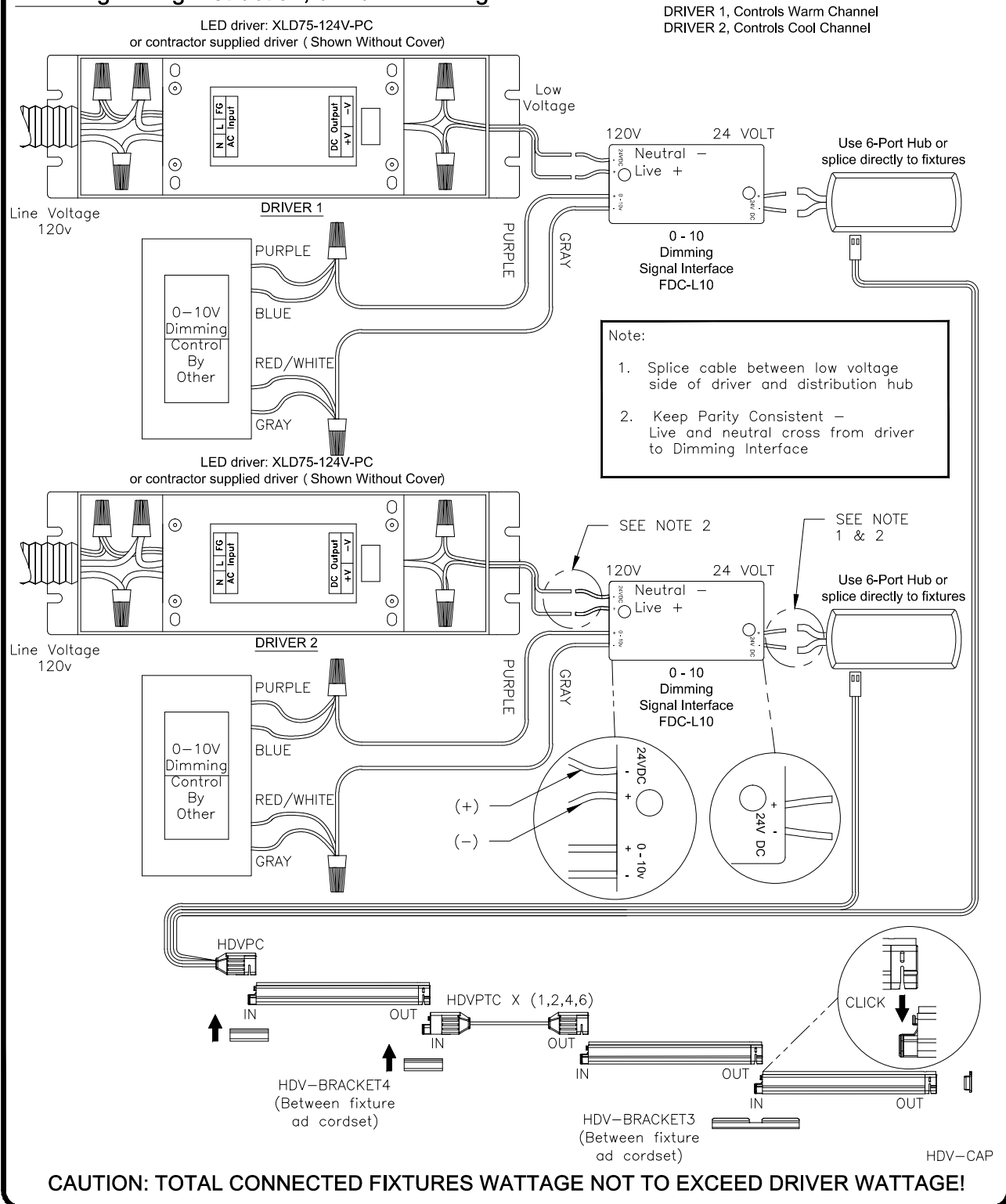

**Step 4. Driver and Fixture Installation (Continued) :
Dimming Wiring Instruction, Forward Phase Dimming**

DRIVER 1, Controls Warm Channel
DRIVER 2, Controls Cool Channel

Note:

POWER CONNECTION

HDVPC and SIDEFEED power cables are 8Ft long.
Splice point connections to be located at 8Ft max from first fixture or sidefeed fixture. Drivers can be remote located.
Contractor to provide low voltage wiring for remote distance application. Contractor must test for 24VDC at all splice points.

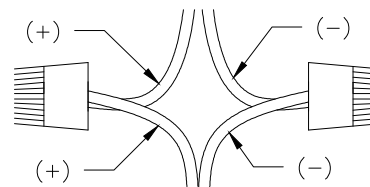
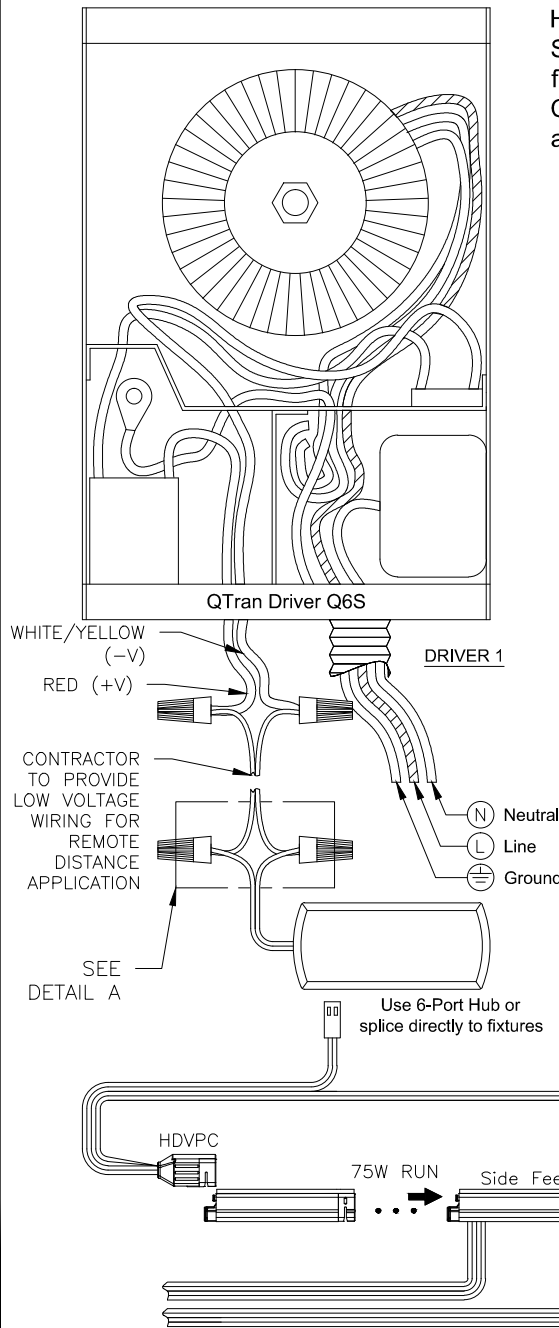

Detail A
HDVPC WIRING
TO QTran Driver

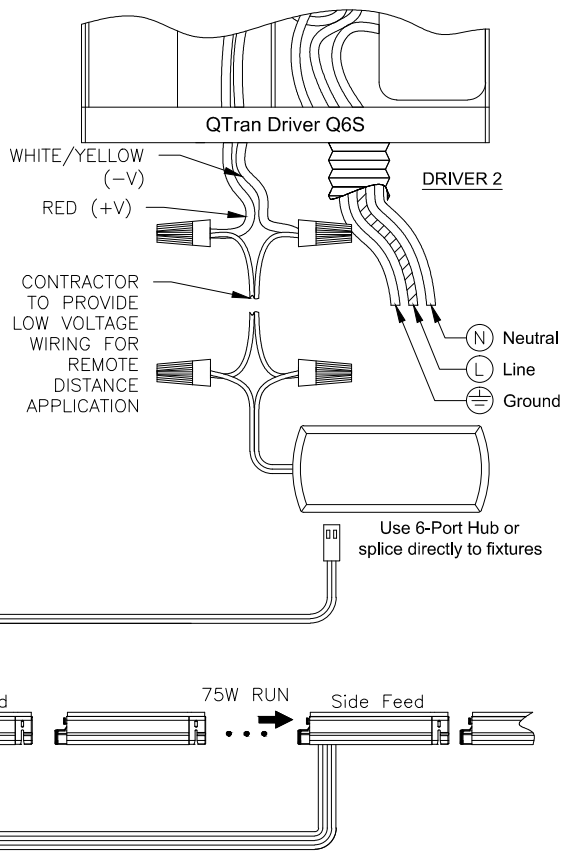

CAUTION: TOTAL CONNECTED FIXTURES WATTAGE NOT TO EXCEED DRIVER WATTAGE!